

WS70

Adjustable 46-69 Kv Jacket and End Stripper

Warning! This tool should not be used on live electrical circuits. It is not protected against electrical shock! Always use OSHA/ANSI/CE or other industry approved eye protection when using tools. This tool is not to be used for purposes other than intended. Read carefully and understand instructions before using this tool.



NOTE: The WS70 tool has been specifically designed for the removal of the polyethylene or PVC outer jackets on 46-69 KV high voltage transmission cables. The tool is also an adjustable end stripper for the same cable.

Cable Range: 1.90" - 3.65" O.D.
Insulation thickness: up to 650 mils

OPERATING INSTRUCTIONS

Before using this tool, insure that the cable end has not been flattened. Use of a hacksaw is recommended.

1. Place the WS 70 over the cable end into the jaws of the tool with the blade facing away from the cable.
2. Adjust the fit of the tool over the cable by turning knurled knob A located at the end of the tool. The fit should allow the tool to rotate freely around the cable.
3. To position stripping blade correctly, adjust the blade depth by turning adjustment knob B . The proper setting is approximately 1/32" above the semi-conductor shielding (fig 1) or the same 1/32" above the conductor when end stripping (fig 2).

Note: The proper blade depth setting is critical for proper operation of the tool. The blade can be permanently damaged if the setting is too deep and cuts into metallic shielding or the center conductor.

4. Once the blade is set, the stripping operation can be performed by applying a slight forward pressure while rotating the tool around the cable in a clockwise direction. Continue this procedure until the desired amount of jacket material has been removed.

Note: It is advisable to "train" the jacket curl so it does not wrap around the cable.

5. A cable clamp or other stopping device will assist as a tool "stop" in order to produce a square end cut as the tool rotates against it on the last tool turn. If manually ending the strip, exert back force during the last tool turn to square off the cut.

See table below for the WS70 model best suited for cable stripping needs. The blades are interchangeable between the tool models

Tool Model	Tool Part No.	Blade Model	Use
WS70	42040	CB 265	General purpose stripping with conservative feed best suited for cable outer jackets and some XLPE insulation removal
WS70-1	42040-1	CB265-2	Designed with a more aggressive stripping feed for faster insulation removal on XLPE and most EPR insulated cables.
WS70-2	42040-2	CB265-4	Designed with most aggressive stripping feed for soft EPR insulations. This tool model was specifically developed for Kerite EPR insulated cables.

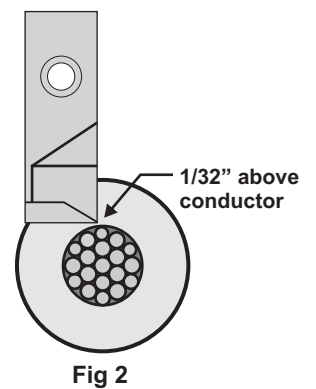
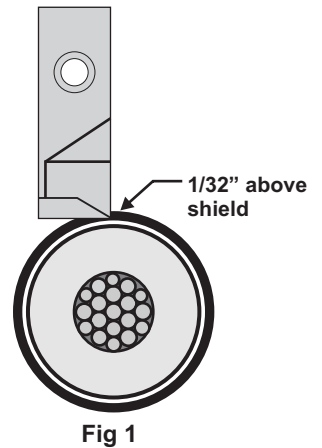

WARRANTY: RIPLEY warrants its products against defective materials and workmanship for a period of one year from date of shipment from the RIPLEY factory provided the product is utilized in accordance with instructions and specified ratings.



46 Nooks Hill Road, Cromwell, CT 06416 USA ~ Phone: 800-528-8665 ~ Int'l: (01) 860-635-2200
Fax: (01) 860-635-3631 ~ E-mail: info@ripley-tools.com ~ Internet: www.ripley-tools.com



42048 rev2
06-13-19